

E92 Flex Fuel Pin Location

Connector 1 (Blue)

Pin 38

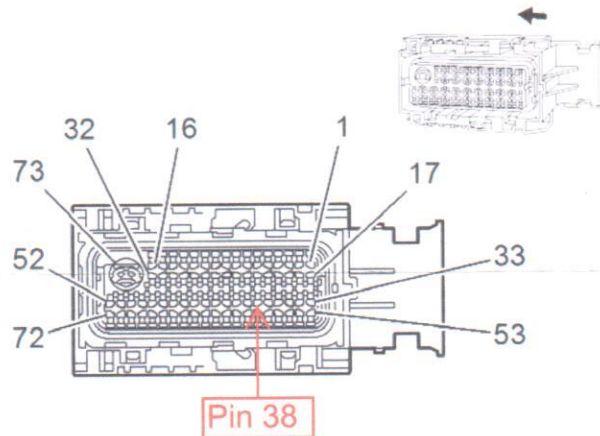

1. With the car off and in a well ventilated area, use the supplied fuel line disconnect tool to unhook the fuel line from the fuel rail (some fuel will spill out).
2. Clip the flex fuel kit female end onto the fuel rail, and hook the factory fuel line onto the sensor. There will be an audible click, and the factory retainer clip will not be reused.
3. Unplug the nearest ignition coil connector and plug the supplied jumper harness inline. The three-pin connector will go to the flex fuel sensor.
4. Unplug the connector from the ECM (pull the red lock tab back first, then push down the release in front of the lever).
5. Remove the back cover from connector (snip the zip tie if you want to be able to move wires).
6. **With a small screwdriver or flat blade, pry the terminal lock off the connector. ****
7. Using tweezers or needle nose, remove the cavity plug from pin 38 (or push through).
8. Looking at other terminals in the connector, insert the Flex Fuel terminal into the back side of the connector and push down all the way to seat. Verify it is seated like the existing terminals.
9. Push the connector face back on, snap the back cover on, and reconnect the connector to the ECM.

****IF YOU DO NOT REMOVE THIS TERMINAL LOCK PRIOR TO INSERTING THE TERMINAL, IT WILL NOT SEAT COMPLETELY AND THE SENSOR WILL NOT WORK**